



MAX4144 Evaluation Kit

General Description

The MAX4144 evaluation kit (EV kit) simplifies evaluation of the MAX4144 high-speed differential line receiver. The EV kit circuit demonstrates the MAX4144 set to a fixed gain of 2V/V.

Features

- ◆ 130MHz Bandwidth (-3dB)
- ◆ Fully Assembled and Tested

Component List

DESIGNATION	QTY	DESCRIPTION
C1, C2, C3, C4	4	0.1 μ F, 10% ceramic capacitors Vitramon VJ1206Y104KXX
C5, C6	2	10 μ F, 10V, 20% tantalum capacitors AVX TAJB106M010 Sprague 293D106X0010B
IN+, IN-, OUT	3	SMA connectors
JU1	1	3-pin header
R1, R2, R3	3	49.9 Ω , 1% resistors
RG	1	Open
U1	1	MAX4144ESD
None	1	MAX4144 PC board
None	1	MAX4144 data sheet
None	1	Shunt for JU1

Component Suppliers

SUPPLIER	PHONE	FAX
AVX	(803) 946-0690	(803) 626-3123
Sprague	(603) 224-1961	(603) 224-1430
Vishay/Vitramon	(203) 268-6261	(203) 452-5670

Ordering Information

PART	TEMP. RANGE	BOARD TYPE
MAX4144EVKIT-SO	+25°C	Surface Mount

Quick Start

The MAX4144 EV kit is fully assembled and tested. Follow these steps to verify board operation. **Do not turn on the power supply until all connections are completed.**

- 1) The circuit requires supply voltages of ± 5 V. Connect ± 5 V supplies to the corresponding pads marked VCC and VEE. Connect the power-supply ground to the pad marked GND.
- 2) Verify that there is a shunt across pins 1 and 2 of jumper JU1.
- 3) Apply signals to IN+ and IN- whose differential voltage does not exceed ± 1.5 V. These signals must not exceed the amplifier's input common-mode range of ± 2.8 V.
- 4) Connect the output marked OUT to an oscilloscope through a terminated 50 Ω cable.
- 5) Turn on the power supply and verify the output signal on the oscilloscope.

Evaluates: MAX4144

MAX4144 Evaluation Kit

Detailed Description

Shutdown Control

The MAX4144 provides a SHDN pin to disable the output. Table 1 lists the options available for the shutdown-control jumper, JU1. To use an external controller, completely remove the shunt on JU1 and connect the external controller to the pad labeled SHDN. SHDN is a TTL/CMOS logic-level input.

Table 1. Jumper JU1 Functions

SHUNT LOCATION	SHDN PIN	MAX4144 OUTPUT
1 & 2	Connected to GND	MAX4144 enabled
2 & 3	Connected to VCC	Shutdown mode

Reference

The MAX4144 REF pin is shorted to ground on the EV board. The connection to ground can be easily broken by cutting the PC board trace between jumper JU2's pads. The REF pad allows easy access to the REF pin.

Layout Considerations

The MAX4144 EV kit layout is optimized for high-speed signals and low distortion, with careful attention given to grounding, power-supply bypassing, and signal-path layout. The small, surface-mount, ceramic bypass capacitors (C1, C2, C3, and C4) are placed as close to the four MAX4144 supply pins as possible. The ground plane has been removed around and under the MAX4144 to reduce stray capacitance. The removal of ground plane around the input SMA connectors reduces distortion.

MAX4144 Evaluation Kit

Evaluates: MAX4144

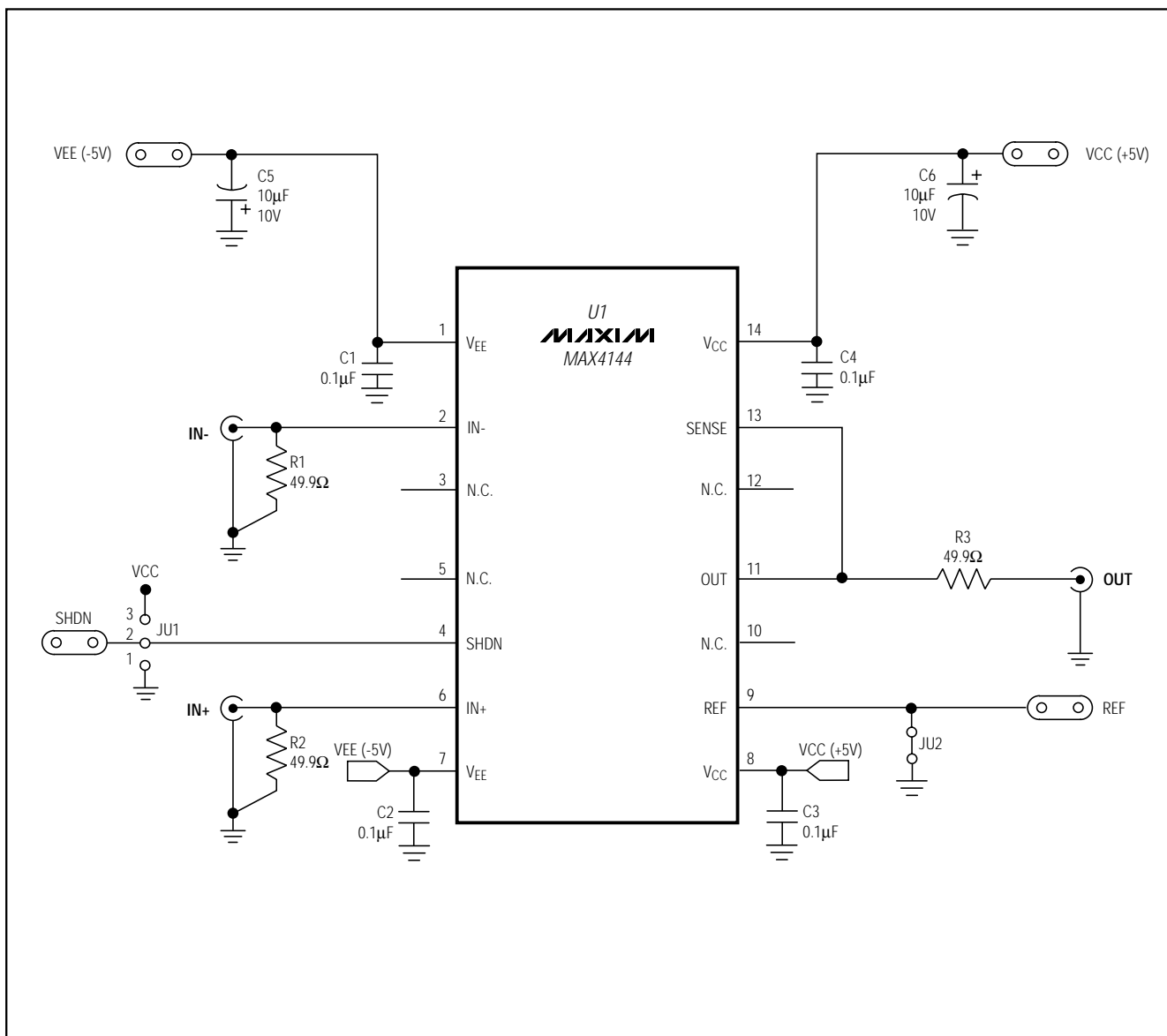

Figure 1. MAX4144 EV Kit Schematic

MAX4144 Evaluation Kit

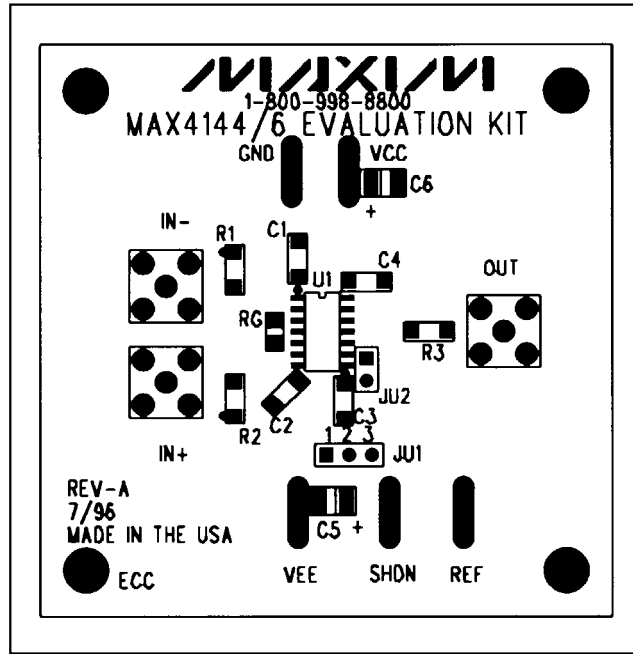

Figure 2. MAX4144 EV Kit Component Placement Guide—Component Side

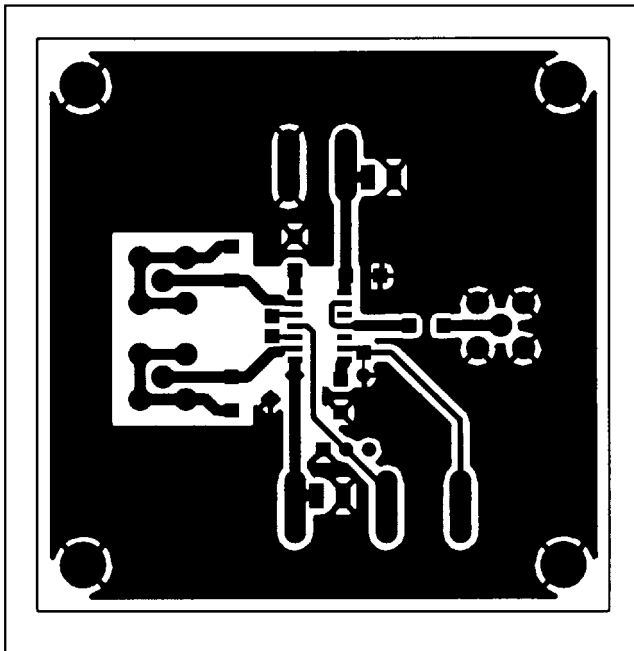

Figure 3. MAX4144 EV Kit PC Board Layout—Component Side

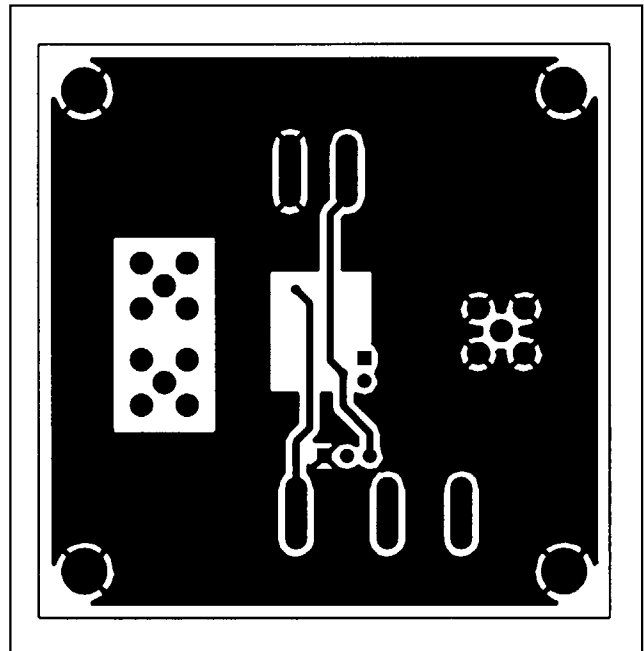

Figure 4. MAX4144 EV Kit PC Board Layout—Solder Side

Maxim cannot assume responsibility for use of any circuitry other than circuitry entirely embodied in a Maxim product. No circuit patent licenses are implied. Maxim reserves the right to change the circuitry and specifications without notice at any time.

4 _____ Maxim Integrated Products, 120 San Gabriel Drive, Sunnyvale, CA 94086 (408) 737-7600